

## Simplex filter EG2

Flanged connection, rated pressure up to 16 bar (232 psi)  
Connection sizes: DN 20 to DN 150, cast design

### 1. Features

#### High-performance filters for modern systems

- Entry-level model among MAHLE Industrial Filtration products
- Used as a protective or safety filter in shipping and industry
- Simple, robust design
- Compact design
- Minimal pressure drop through optimal flow design
- Elements with high differential pressure stability and dirt holding capacity
- Filter ratings from 25 to 5000  $\mu\text{m}$  absolute, other ratings on request
- Suitable for use with fluids of all types
- Easy service
- Worldwide distribution



## 2. Operating principle

- The medium flows through the filter element (perforated, smooth or pleated) from the inside to the outside.
- Contaminants are trapped on the inside of the element.
- The filtration process is interrupted when a settable fouling threshold is reached.
- The filter is opened and the element removed for cleaning.
- Simplex filters require no maintenance apart from cleaning the filter elements and inspecting the seals.

## 3. Technical Data

Connection:	DN 20 to DN 150
Flange:	DIN 2501 PN 16
Material:	Nodular cast iron 40, CrNi-Guss 1.4581 (nur bis DN 100)
Max. operating pressure:	16 bar
Test overpressure:	21 bar
Max. operating temperature:	180 °C
Filter element:	Screen basket, cartridge
Filter rating:	25 to 5000 µm absolute, other ratings on request

## 4. Dimensions

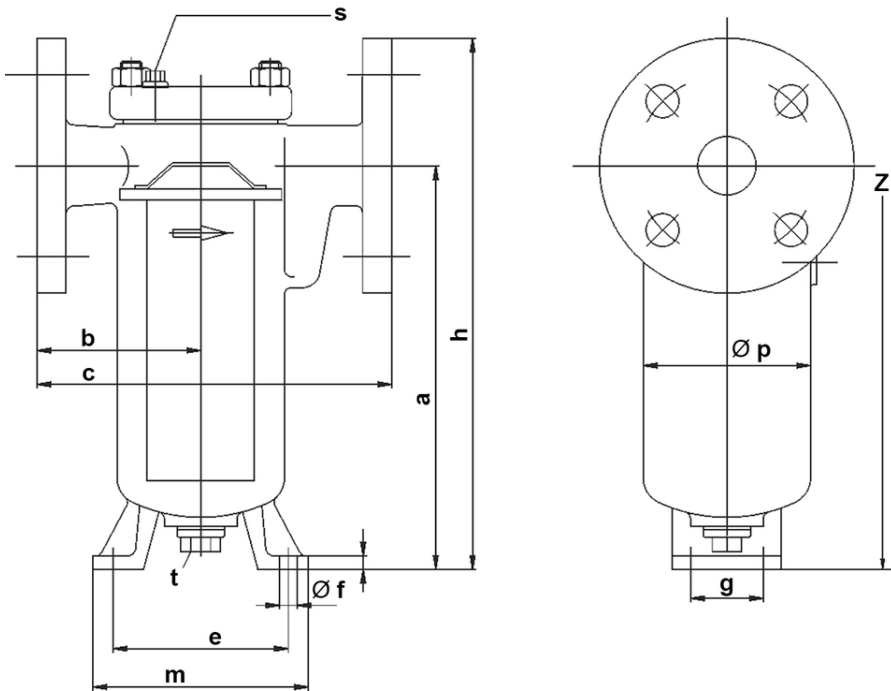

s = Vent  
t = Drain  
Z = Clearance required

All dimensions except "s" and "t" in mm.

Type	DN	a	b	c	m	e	ø f	g	h	l	ø p	s	t	Z	Weight [kg]
AE033210A02*	20	136	75	160	-	-	-	-	189	-	70	G1/8	G¾	285	5
AE043210A03*	25	162	85	180	-	-	-	-	219	-	92	G1/8	G¾	338	8
AE053210A04*	32	214	90	195	-	-	-	-	284	-	92	G1/8	G¾	424	10
AE063210A05*	40	263	105	230	-	-	-	-	337	-	126	G1/4	G1	523	13
AE073210A05*	50	263	105	240	-	-	-	-	346	-	126	G1/4	G1	523	16
AE083210A07	65	340	115	275	160	130	14	60	433	14	146	G1/4	G1	719	30
AE093210A08	80	390	130	325	210	170	18	60	490	16	178	G1/4	G1½	839	42
AE103210A09	100	480	145	365	220	180	18	70	590	16	204	G1/4	G1½	1018	64
AE113210A10	125	660	190	480	260	220	18	170	785	18	260	G3/8	G1½	1343	97
AE123210A11	150	760	210	530	320	270	23	200	903	20	308	G3/8	G1½	1534	136

\* type without feet

## 5. Design and application

A wide range of filter elements are available for every filter. The material, type of construction and filter surface and rating are expertly adapted to the specific filtration task based on the medium and capacity.

Each filter can be supplied with various options to ensure the optimum performance for each particular application.

Options:

- Heating with steam/thermal oil or electric
- Magnetic elements
- Differential pressure indicator/switch as a removable part
- Internal coating or rubber coating

Simplex filters are not at all complicated to use. The necessary steps are described in the following:

- The filter comprises a cylindrical housing, a cover and a filter element. It is fitted with a vent screw and a drain plug.
- Stress relief must be provided for all pipe connections. The filter must be filled and vented before it is put into service. Install the filter piping so that the medium flows through the filter in the direction indicated by the arrow.
- During the filtration process, the medium flows through the filter element from the inside to the outside. Contaminants are trapped on the inside of the element. As the filter element becomes increasingly dirty, the flow resistance rises accordingly. The degree of fouling is indicated on the differential gauge (optional). The filter element must be cleaned when the pressure difference reaches 0.7 bar.
- In order to remove the filter element, loosen the cover fastening nuts on the depressurised filter and lift off the cover. The dirty element can then be withdrawn without any problems.
- To clean the filter element, either blow it out with compressed air, steam or water or brush it with a soft brush. Be careful not to damage the filter fabric or the perforated sheet and avoid pushing the element inwards as it is blown out. Pre-treat the element with a suitable solvent if the dirt deposits cannot be removed easily.

## 6. Type number key

### Type number key with selection example for EG2 simplex filter with DN 20 to DN 150

#### Main product group

A Simplex filter, cast design

#### Series

E Simplex filter with filter element or cartridge

#### Inlet and outlet connections

03 Flange DN 20

06 Flange DN 40

07 Flange DN 50

08 Flange DN 65

09 Flange DN 80

10 Flange DN 100

11 Flange DN 125

12 Flange DN 150

#### Filter connection standard + rated pressure

3 EN 1092 PN 16 bar

#### Position of main connections

2 Opposite each other on the same side

#### Cover fastening

1 Stud bolts or hexagon screws

#### Options

0 Standard version

2 Electric cartridge heater

3 Steam/thermal cartridge heater

7 Version without non-ferrous metals

G Rubber coating

#### Type of inner assembly

A Filter elements for simplex filter

#### Inner assembly size

XX

#### Housing version

2 Nodular cast iron

#### Nozzle material

0 No material specified (not assigned)

#### Number of special types or design features

XX

A E 09 3 2 1 0 A 08 2 0 00